

LEISTER®

GB USA

VARIMAT V2



Leister Process Technologies
Galileo-Strasse 10
CH-6056 Kaegiswil/Switzerland
Tel. +41-41662 74 74
Fax +41-41662 74 16
www.leister.com
sales@leister.com

Congratulations on purchasing a VARIMAT V2 kit!









You have chosen a top-class hot-air tool kit made of high-quality materials. Every VARIMAT V2T kit undergoes stringent quality checks before leaving the factory in Switzerland.

Table of Contents

Quick Info	Page	2
Application, Maintenance, Caution	Page	3
Conformity, Disposal, Technical Data	Page	4
Device Description, Controls	Page	5
Joining Force, Operational Availability, Sensor Setting	Page	6
Sensor Setting	Page	8
Work Mode (Chapter 3)		
3.1 Setpoint Value Display		
3.2 Work Display	Page	9
3.3 Setting the Drive Speed		
3.4 Setting the Welding Temperature	Page	10
3.5 Setting the Air Volume		
3.6 Length Measurement	Page	11
3.7 Selecting Profiles		
3.8 Cooling Down	Page	12
3.9 Standby		
3.10 Error Messages	Page	13
Profile Setup (Chapter 4)		
4.1 Creating Profiles		
4.2 Standby Setup	Page	14
Percent Mode (Chapter 5)		
5.1 Creating Profiles	Page	14
Accessories, Training, Maintenance, Service and Repair, Warranty	Page	15

Quick Info

How do I start the hot-air welding machine VARIMAT V2?

1. Establish power supply cord to the electrical mains 
2. **Main switch (3) ON** 
3. Press Drive key  Turn e-Drive 
4. Press Heating key  Turn e-Drive 
5. Press e-Drive  Heating up time approx. 3 – 5 minutes 
6. Carry out a test weld according to the welding instruction of the material manufacturer and national standards or guidelines. Check test weld.
7. Welding 

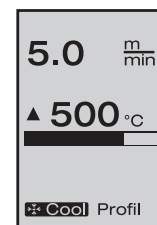

How do I switch off the hot-air welding machine VARIMAT V2?

1. Press e-Drive  
2. Press «Cool down OK» e-Drive  and allow to cool approx. 5 minutes
3. After **welding nozzle (9)** has cooled down, **main switch (3) OFF** 

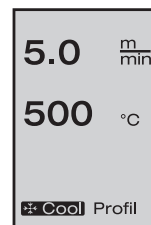



Please read operating instructions carefully before use and keep for future reference.

Leister VARIMAT V2 Hot-Air welding machine

Application

- Overlap welding of roof sheeting made from PVC, TPO, ECB, EPDM, CSPE for basic weld seams.
Can also be used in areas close to edges and on uneven surfaces.
- Overlap welding of sheets and coated fabrics



Warning



Danger to life if you open the equipment, since this reveals current-conducting components and connections.
Remove the mains plug from the plug socket before opening the equipment.



Incorrect use of the hot air tool can present a **fire and explosion hazard** especially near combustible materials and explosive gases.



Do not touch the element housing and nozzle when hot as they can cause **burns**.
Allow the tool to cool down. Do not point the hot air flow at people or animals.



Connect tool to a **receptacle with protective earth terminal**. Any interruption of the protective conductor inside or outside the tool is dangerous!
Use only extension cables/cords with protective conductor!



Caution



The mains voltage, that is quoted on the equipment must agree with the mains voltage.
Move out hot-air blower upon mains failure.



For personal protection, we strongly recommend the tool be connected to an **RCCB (Residual Current Circuit Breaker)** before using it on construction sites.



The tool must be operated **under supervision**.
Heat can ignite flammable materials which are not in view.
The machine may only be used by **qualified specialists** or under their supervision.
Children are not authorized to use this machine.



Protect the tool **from damp and wet**.



The equipment must not be lifted using the additional weight.

Conformity

Leister Process Technologies, Galileo-Strasse 10, CH-6056 Kaegiswil/Switzerland confirms that this product, in the version as brought into circulation through us, fulfils the requirements of the following EC directives.

Directives : 98/37, 89/336, 73/23

Harmonised standards: EN 292-1, EN 292-2, EN 60204-1, EN 55014-1, EN 55014-2, EN 61000-3-2, EN 61000-3-3, EN 50366, EN 60335-2-45

Kaegiswil, 28.08.2009



Bruno von Wyl
Technical Director



Christiane Leister
Owner

Disposal



Power tools, accessories and packaging should be sorted for environmental-friendly recycling. **Only for EC countries:** Do not dispose of power tools into household waste! According to the European Directive 2002/96/ on waste electrical and electronic equipment and its incorporation into national law, power tools that are no longer suitable for use must be separately collected and sent for recovery in an environmental-friendly manner.

Technical data

Voltage	V~	230, 400 ★	V~	230, 400 ★
Power consumption	W	4600, 5700	W	4600, 5700
Frequency	Hz	50/60	Hz	50/60
Temperature	°C	20 – 620 stepless	°F	212 – 1148 stepless
Drive	m/min.	0,7 – 12 stepless	ft/min	2.3 – 39.4 stepless
Welding pressure	N	ca.190 (2 weights)	N	ca.190 (2 weights)
Air flow	%	50 – 100	%	50 – 100
Emission level	L_{PA} (dB)	68	L_{PA} (dB)	68
Weight	kg	35	lbs	77
without power supply cord				
Dimensions L×W×H	mm	650 × 430 × 330	inch	25 × 17 × 13
Mark of conformity	CE			
Approval mark	S			
Certification scheme	CCA			
Protection class I	⊕			

Technical data and specifications are subject to change without prior notice.

★ Mains voltage cannot be switched over

Description of tools

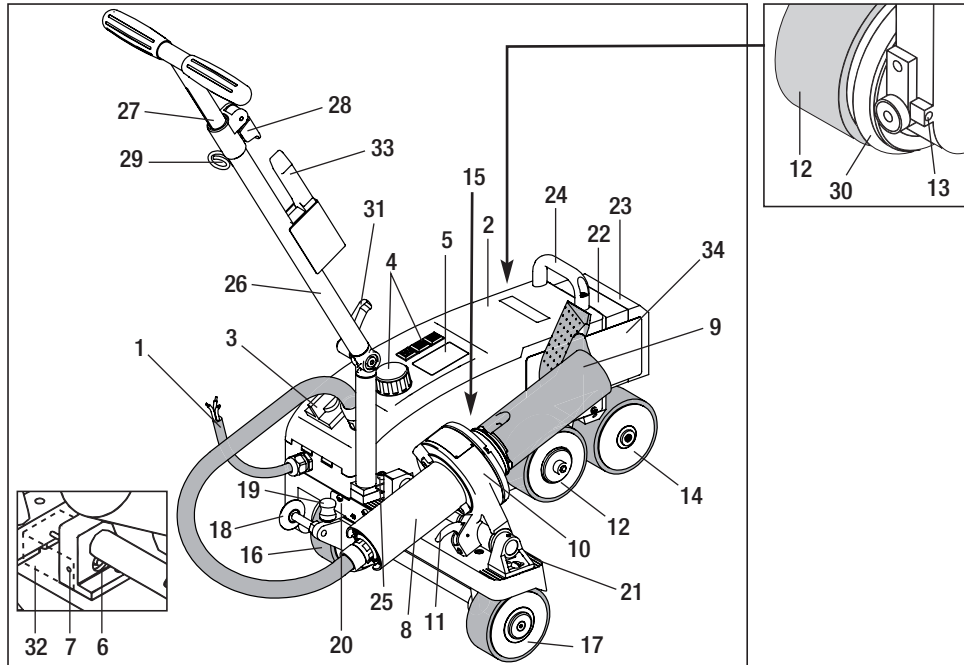

- | | | |
|----------------------------|---------------------------------------|---|
| 1. Power supply cord | 13. Adjustment screw for tracking | 25. Fillister head screw |
| 2. Housing | 14. Track-alignment roller | 26. Lower guide bar |
| 3. Main switch | 15. Guide roller | 27. Upper guide bar |
| 4. Controls | 16. Adjustable transport roller | 28. Clamping lever guide bar
height adjustable |
| 5. Display | 17. Transport roller | 29. Holder for power supply cord |
| 6. Sensor | 18. Guide roller | 30. Round belt |
| 7. Locking screw | 19. Shift spring for transport roller | 31. Clamping lever guide bar |
| 8. Hot air blower | 20. Gate | 32. Sensor covering |
| 9. Welding nozzle | 21. Scale for tool adjustment | 33. Wire brush |
| 10. Tool holder | 22. Additional weight | 34. Welding plate |
| 11. Locking lever | 23. End weight | |
| 12. Pendulum action roller | 24. Carrying handle | |

Controls (4)



Main switch (3)

For switching the hot-air welding machine VARIMAT V2 on/off



e-Drive

The e-Drive serves as a navigator. It has two functions



Turn left or right, in order to set diverse menus or values



Press to confirm or to activate



Drive

Setting the drive speed



Heating

Setting the welding temperature



Blower

Setting the air volume

Welding pressure

- The welding pressure is transmitted to the **pendulum action roller (12)**.
- As necessary, the **additional weights (22)** and the **end weight (23)** can be put on (see illustration H).

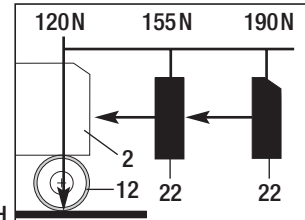

Illustration H

Operating condition

- Before putting into operation, check **power supply cord (1)** and connector as well as extensive cable for electrical and mechanical damage.
- Move **guide bar (26/27)** to required position using the **clamping lever (28/31)**.
- Hang strain relief of **power supply cord (1)** in **holder (29)**.
- Check the basic setting of the **welding nozzle (9)**.
(ex works illustration A and C)
- **Transport setting**
 - Swivel the **guide roller (18)** upwards
 - Release the **transport roller (16)** by raising the **guide bar (27)**.
 - Push the **transport roller (16)** by applying a little pressure to the **shift spring (19)** to the left until it stops (illustration B).
 - Position the **hot air blower (8)** by pulling the **locking lever (11)** and swivel it up until it locks.
- Connect VARIMAT V2 to the electrical mains. The mains voltage must correspond to the device voltage.



Illustration A 2.5 mm

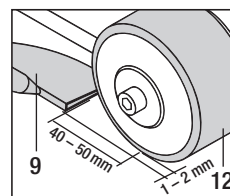

Illustration C

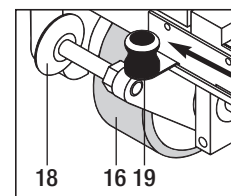

Illustration B

Sensor Setting

Automatic starter reason for fault

- Drive motor **does not start automatically** after the nozzle has been positioned
 - **Sensor (6)** set incorrect



Allow the **welding nozzle (8)** to cool.

Action adjust Sensor

- **Sensor (6)** adjustment:
 - Switch off **main switch (3)**
 - **Remove sensor covering (32)**
 - Lower the **hot air blower (8)** and guide it to the left until it locks
 - **Locking lever (11)** must click in
 - Loosen **locking screw for sensor (7)**
 - Push **sensor (6)** to **tool holder (10)**. **IMPORTANT!** Distance between tool holder and sensor > 0,2 – 0,5mm max.
 - Tighten **locking screw for sensor (7)**
 - Fix **sensor covering (32)**
 - Move the **hot air blower (8)** out until it locks and swivel up
 - Make a functional test
- **If malfunction is still present, contact your Service Center.**

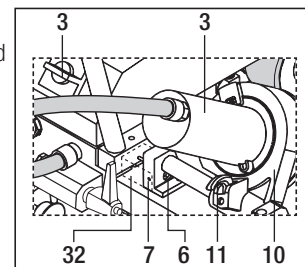

Tool positioning

- Lift hot-air welding machine with pressure onto **guide bar (27)** and move to weld position.



Take **welding plate (34)** from holder and position according to Illustration H.

WARNING: The **welding plate (34)** may only be removed from the holder and positioned if the **welding nozzle (9)** has cooled down.

- Release the **transport roller (16)** by lifting it with the **guide bar (27)**.
- Push the **transport roller (16)** to the left until it stops by applying light pressure to the **shift spring (19)**.
- Swivel the **guide roller (18)** down.
- The **guide roller (18)** should be set parallel to the edge of the **pendulum action roller (12)** (see illustration E).
- Do a test run
- To correct the tracking, adjust the **adjustment screw for tracking (13)** (see illustration F and G, and the function notes on the automatic welding machine).

Illustration E

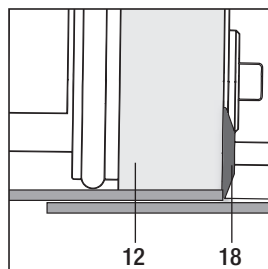

Illustration F

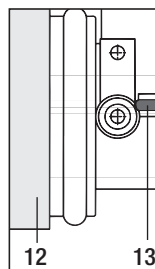

Illustration G

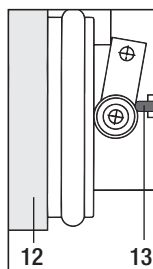
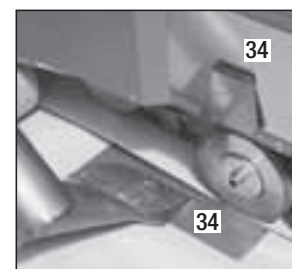

Illustration H



Welding Workflow



Perform a test welding according to the welding instructions of the material manufacturer and the national standards or guidelines. Check the test welding.

- Set welding parameters (drive, heating and blower), see Chapter 3 Work Mode.
- Welding temperature must be reached (heating up time approx. 3 – 5 min).
- Pull **locking lever (11)**, lower **hot-air blower (8)** and move in between the overlapping sheets as far as the limit stop. Drive motor starts automatically.
No automatic start, see **Sensor (6)** Setting.
Machine can be started manually with the **controls (4)** Drive and e-Drive .
- The welding machine is guided along the overlap at the **guide bar (27)**. No pressure on **guide bar (27)**, this could lead to welding problems. Observe position of the **guide roller (18)**.
- After the welding, pull **locking lever (11)**, move out **hot-air blower (8)** as far as the limit stop and swivel up to the latching point.
- After finishing the welding work, switch off heating with e-Drive (press 2 x).
This allows the **welding nozzle (8)** to cool down.
- After the **welding nozzle (8)** has cooled down, the blower switches off automatically after approx. 4 minutes.
- Turn off **main switch (3)** .
- Clean **welding nozzle (8)** with **wire brush (33)**.

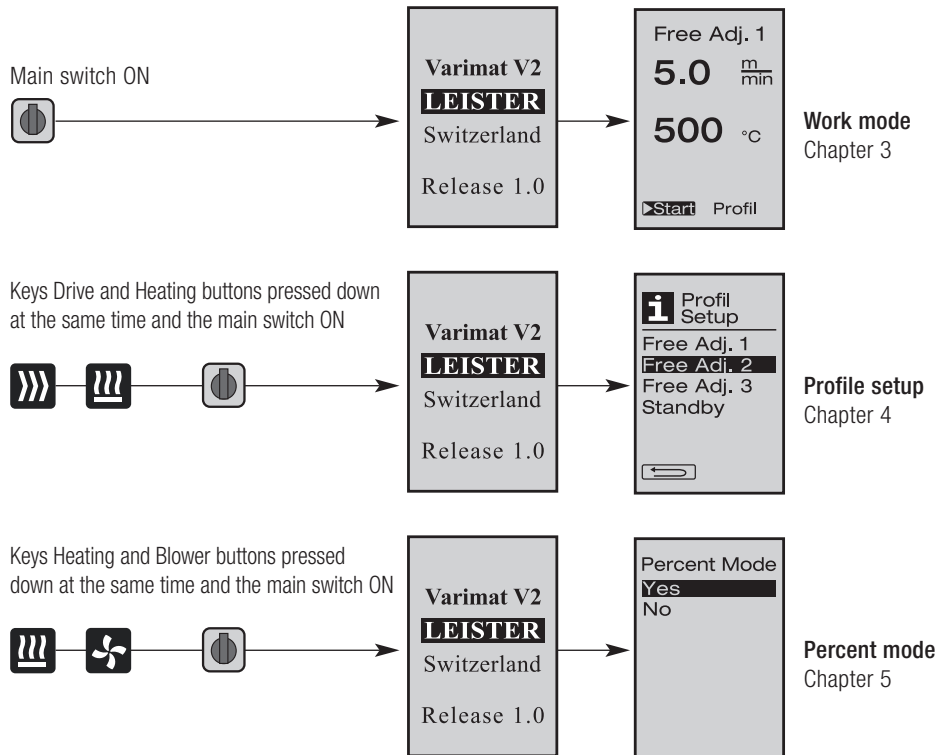

Startup Combination



3. Work Mode

3.1 Setpoint Value Display (after switching on the device)

Main switch (3) ON

- After switching on the device, the Overview (Fig. 1) appears on the **display (5)**.
- If $<80^{\circ}\text{C}$ appears on the **display (5)**, the **welding nozzle (9)** will have cooled down.
- The heating and drive are switched off in this menu.
- The user can use the **controls (4)** here to perform all settings which are described in the following chapters.
- However, if the heating element temperature is greater than 80°C when switching on, the display will immediately change to Cool Down mode (Chapter 3.8 Cooling Down) in which the blower is always operated at full power and hence the **welding nozzle (8)** is cooled down.
- It is possible to change back to Work mode from this mode at any time, however.
- If the heating element temperature reaches 60°C , the blower will continue to operate for about 2 min. and then switch off automatically again. The **display (5)** changes back to the setpoint value display (Fig. 1).
- Pressing the e-Drive  starts the heating and blower (if they are still switched off) and the display changes to a mode described in Chapter 3.2 Work Display (Fig. 2).
- In addition, turning the e-Drive  to Profile allows the various welding profiles to be selected (Chapter 3.7 Selecting Profiles, Fig. 3).

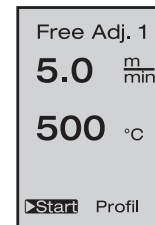

(Fig. 1)





(Fig. 2)



(Abb. 3)





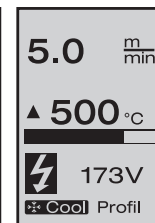
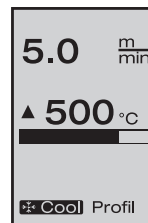
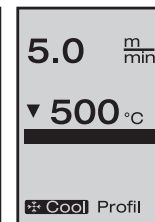
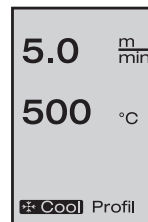





3.2 Work Display

- The heating and blower are active in Work mode.
- The drive starts after the wedge has been moved into the welding position or if the drive is manually switched on via the Drive menu (Chapter 3.3 Setting the Drive Speed).
- If no button is pressed for a definite period of time (**welding nozzle (9) NOT in welding position**), the Standby menu (Chapter 3.9 Standby) will be called up.
- If the mains voltage is outside (-13% / +15%) the specified nominal voltage (230V or 400V), this is displayed with the  173V symbol and the measured undervoltage/overvoltage.
- The VARIMAT V2 continues the work.
- Depending on the undervoltage/overvoltage, the welding result can be affected.
If the blower power is less than 100%, the set blower power changes with the  173V symbol.
- If the **welding nozzle (9)** is heating up, this is displayed on the display with the progress bar, arrow (up) and actual value of the temperature (flashing).
- If the **welding down (9)** is cooling down, this is shown on the display with full progress bar, arrow (down) and flashing actual value of the temperature.
- If the welding nozzle is not swivelled in, the menu Cool Down (Chapter 3.8 Cooling Down) and Profiles (Chapter 3.7 Selecting Profiles) can be selected via the e-Drive **controls (4)**. If the **welding nozzle (9)** is swivelled in, the two menu items disappear and can therefore no longer be selected.







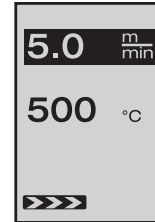

3. Work Mode

3.3 Setting the Drive Speed

- The Drive key  can be used to adjust the welding speed or the drive speed. This can be set by turning the e-Drive  in 0.1 m/min. increments from 0.7 m/min. – 12.0 m/min. This setting can be carried out with the drive switched on or switched off.
- If the **welding nozzle (9)** is not in the welding position, the symbol  will appear at the lower left edge of the **displays (5)**.
- The drive can be switched on by pressing the e-Drive  and the symbol **Stop**  will appear. The speed can be set by turning the e-Drive .
- Pressing the e-Drive  again executes the Stop command, which switches off the drive. The Setpoint Value display or Cool Down appears on the display.
- If no entry is made by the **controls (4)** within 3 seconds, the new drive speed will be accepted. The Setpoint Value display or Cool Down appears on the **display (5)**.
- If the Drive key  is pressed for 3 seconds, the display will change to another menu (see Chapter 3.6 Length Measurement, Service / Blower and Drive Counter). You can change to the relevant menu from this menu by pressing the Heating key  or Blower key .







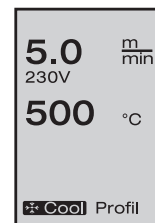
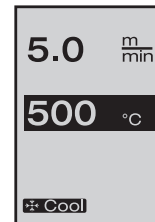

3.4 Setting the Welding Temperature

- The heating temperature can be changed with the Heating key . The temperature can be set in 10°C increments from 100°C – 620°C by turning the e-Drive . The setting is accepted after 3 seconds, as long as no button is pressed within these 3 seconds.
- The Cool Down menu (Chapter 3.8 Cooling Down) can also be selected here.
- Pressing the Heating key  for 3 seconds changes the **display (5)** to Work mode. The mains voltage appears below the drive speed. This call is only possible from the Work display Chapter 3.2. A call from the Setpoint Value display or from the Cool Down display is not possible.
- In case of a set temperature of 500°C and higher, the blower power is automatically adjusted, if necessary. The adjustment only occurs if the set blower power is higher than the suggested value. This adjustment is necessary in order to be able to reach higher temperatures (> 500°C). However, the user can adjust the blower power to any value via the Blower key  (see Chapter 3.5, Setting the Blower Power). You can change to the relevant menu from this menu by pressing the Drive key  or Blower key .





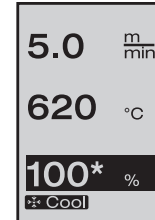

3. Work Mode

3.5 Setting the Air Volume

- Work mode allows the power of the blower to be changed using the Blower key  . The blower power can be set in 5% increments from 50% – 100% by turning the e-Drive  . The setting is accepted after 3 seconds, as long as no button is pressed within these 3 seconds. If the blower power is set to 100%, no display will appear on the displays (5).
- If the blower power is automatically reduced when setting the air temperature, the blower power can be increased manually by turning the e-Drive  . If the set blower power is higher than the suggested value, a star **100*** will appear next to the number. In this case, 100%* will also be shown on the display (5).
- The Cool Down menu can be selected by pressing the e-Drive  (Chapter 3.8, Cooling Down).
- You can change to the relevant menu using the Drive key  or Heating key  .



3.6 Length Measurement, Service / Blower and Drive Counter



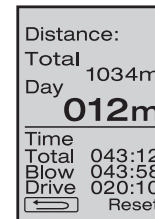







- This menu (Fig. 4) appears if the Drive key  is pressed for at least 3 seconds.
- The menu displays all operating times and the distance which the device has travelled since being switched on. The total distance (here: 1034 m) cannot be changed and shows the entire path taken since starting up. If the value rises above 9999 m, the value is increased by 1 in the Service menu under «View Error» at «Length» and the total distance begins again at 0000 m.
- The daily distance (here: 012 m) is not reset automatically, but instead must be annulled by the user via «Reset» by pressing the e-Drive  .
- The Time values concern the operating time for the individual components of the device. For this, the time «Blow» (here: 0034:58) is assigned to the blower and drive «Drive» (here: 0020:10). This begins to count as soon as the relevant component is switched on. The «Total» times refers to the operating time of the device and counts as soon as the device is switched on via the main switch. The values are displayed in hours and minutes.
- If the Back arrow is selected by pressing the e-Drive  , you will be taken back  to the menu from which the Drive key  has been pressed.



(Abb. 4)

3. Work Mode

3.7 Selecting Profiles







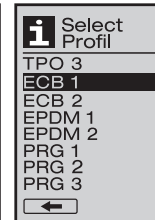
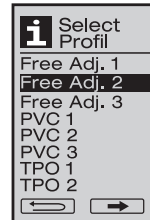
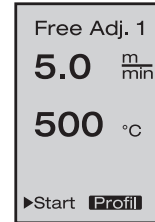

- If the display **Profil** at the bottom right of the **display (5)** is activated, profiles can be loaded by pressing the e-Drive . The display «Select Profile» then appears. A profile can be selected by turning the e-Drive . The profiles Free Adj. 1, 2 and 3 can be defined by the user him/herself (see Chapter 4 Profile Setup). All other profiles have permanently assigned values and cannot be defined by the user.
- Turning the e-Drive  activates left or right arrows on the **displays (5)** at the bottom. Right arrow  by pressing the e-Drive  to the next page. Left arrow  by pressing the e-Drive .
- If the Back arrow  is activated by turning the e-Drive , you will be taken back to the menu by pressing the e-Drive , from which the Profile menu has been selected.



Perform a test welding according to the welding instructions of the material manufacturer and the national standards or guidelines. Check the test welding.



3.8 Cooling Down

- If the symbol **Cool** is selected by pressing the e-Drive , the menu «Cool down OK?» will appear. Pressing the e-Drive  activates the symbol OK at the bottom right of the **display (5)**, thereby initiating the cooling process.
- The instantaneous temperature is displayed during the cooling process. If the temperature falls below 60 °C, the blower will continue for a further 2 minutes and automatically shut off after this time has passed.
- If the Back arrow  is activated by turning the e-Drive , you will be taken back to the menu by pressing the e-Drive , from which the «Cool» menu has been selected.
- If the Cool Down is active, the drive can be switched on/off manually via the Drive key . The Heating key  and Blower key  do not have any function.

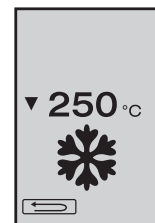
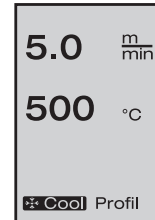

3. Work Mode

3.9 Standby

- If the **welding nozzle (9)** is not in the welding position and no key entry is made during a certain time, the standby process will start automatically after the standby time has passed (5 – 120 min., see Chapter 4.2 Standby Setup) A time of 40 minutes is set ex works. A symbol and a counter (counts down from 180 seconds) appears on the **display (5)**. During this time, the heating is switched on.
- If the time has expired without the controls (4) having been pressed, the **display (5)** will automatically change to Cool Down mode (Chapter 3.8, Cooling Down).
- If the e-Drive  is pressed before the countdown has finished, the display will change back to the initial state.

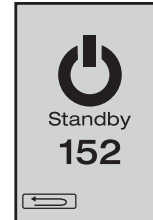

3.10 Error Messages

- If a malfunction occurs in the hot-air welding machine VARIMAT V2, a message will appear on the **display (5)**, which is also provided with an error code. This code stands for a more exact definition of the error which can be seen in the lower list.
- In case of error 02 and error 40, separate symbols are displayed. 
- In case of all other errors, the spanner is displayed for the service prompt.



Error	Type of error
Err01	Interruption or short-circuit of the temperature probe
Err02	Heating element defective (interruption in one/both winding(s))
Err04	Triac defective (one or both Triacs are defective)
Err08	Blower motor defective
Err40	Undervoltage (mains voltage -25%)

4. Profile Setup (see Startup Combination)

4.1 Creating Profiles



- In the Profile Setup, 3 individual profiles can be created in which all three parameters can be freely set and then saved.
- The various menu items can be selected using the **controls (4)**. Pressing the e-Drive  will take you back to the Profile Setup selection.

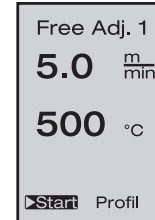
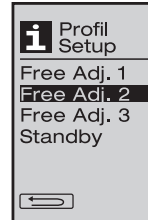

Perform a test welding according to the welding instructions of the material manufacturer and the national standards or guidelines. Check the test welding.



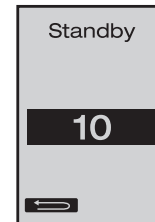

4.2 Standby Setup

- The standby time can be set in this setup. Turning the e-Drive  allows the time to be set from 5 – 120 minutes. Pressing the e-Drive  will take you back to the Profile Setup selection.



5. Percent Mode (see Startup Combination)

5.1 Creating Profiles

- If the Percent mode is selected (see Startup Combination), the Percent mode becomes active after confirming **Yes** by pressing the e-Drive .
- Pressing the e-Drive  again will start the heating and blower. The reference value of the control circuit (in %) for the heating and drive in Work mode becomes visible.
- The mains voltage is also indicated for the user. In this way, the user can estimate what kind of load the controller (heating / drive) is subject to.

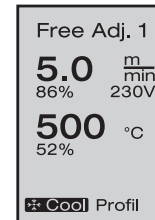
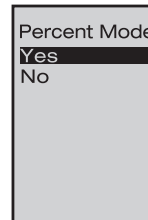

Accessories

- Only Leister accessories should be used.
- Wire brush article no. 138.817
- Welding plate article no. 132.429

Training

- Leister Process Technologies and its authorised Service Centres offer free welding courses and training.

Maintenance

- The air inlet on the **hot-air blower (8)** must be cleaned with a brush if soiled. →
- Clean **welding nozzle (9)** with wire brush.
- Check **power supply cord (1)** and plug for electrical and mechanical damage.



Service and Repair

- If the drive counter reaches 400 h or the blower counter reaches 2000 h, the message «Maintenance servicing» will appear on the display the next time the main switch (3) is switched on. This message is displayed for 10 seconds and cannot be skipped by the **controls (4)**.
- Repairs should only be carried out by authorised **Leister Service Centres**. They guarantee a correct and reliable **repair service within 24 hours**, using original spare parts in accordance with the circuit diagrams and spare parts lists.

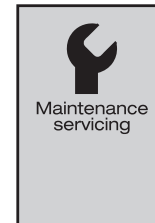

Warranty

- For this tool, we generally provide a warranty of one (1) year from the date of purchase (verified by invoice or delivery document). Damage that has occurred will be corrected by replacement or repair. Heating elements are excluded from this warranty.
- Additional claims shall be excluded, subject to statutory regulations.
- Damage caused by normal wear, overloading or improper handling is excluded from the guarantee.
- Guarantee claims will be rejected for tools that have been altered or changed by the purchaser.



© Copyright by Leister

Your authorised Service Centre is:

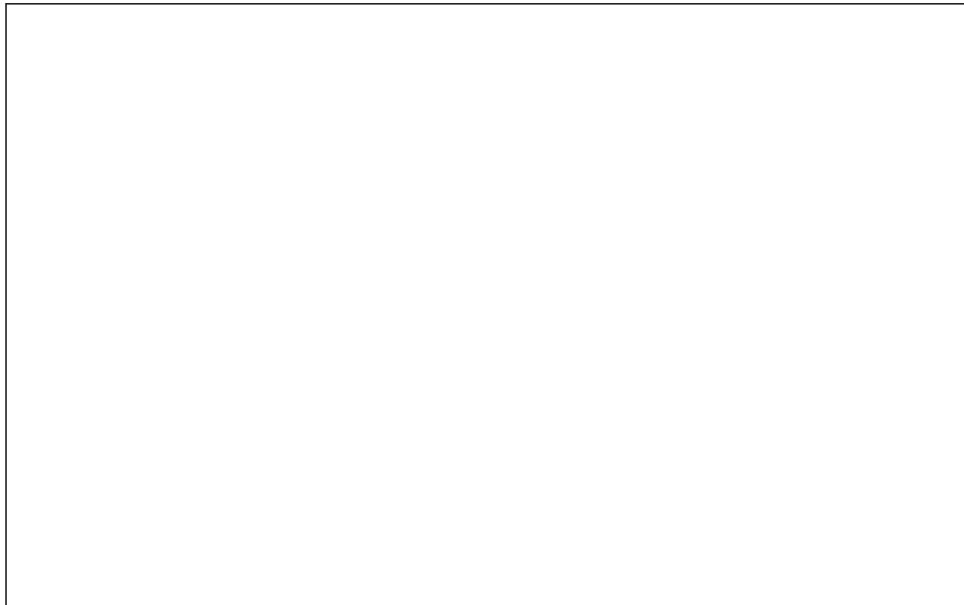

Leister Process Technologies
Galileo-Strasse 10
CH-6056 Kaegiswil/Switzerland
Tel. +41-41662 74 74
Fax +41-41662 74 16
www.leister.com
sales@leister.com

ENG / BA VARIMAT V2 / 08.2009
Art. 139.550