



Z121

12 [305] DIAMETER ROOF DRAIN LOW SILHOUETTE DOME

SPECIFICATION SHEET

TAG _____

Dimensional Data (inches and [mm]) are Subject to Manufacturing Tolerances and Change Without Notice

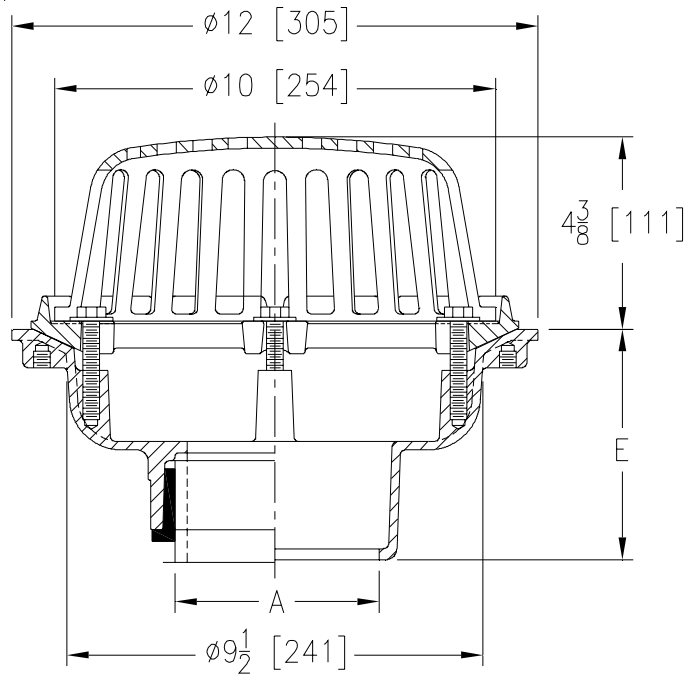

A Pipe Size In.	Approx. Wt. Lbs. [kg]	Dome Open Area Sq. In. [cm ²]
2 thru 6 [51 thru 152]	22 [10]	78 [503]

ENGINEERING SPECIFICATION: ZURN Z121

12 [305] Diameter roof drain. Dura-Coated cast iron body with combination membrane flashing clamp/gravel guard and low silhouette cast iron dome.

OPTIONS (Check/specify appropriate options)

PIPE SIZE

- 2 thru 6 [51 thru 152]
- 2 thru 6 [51 thru 152]
- 2 thru 6 [51 thru 152]
- 2-3-4 [51-76-102]

(Specify size/type) OUTLET

- _____ IC Inside Caulk
- _____ IP Threaded
- _____ NH No-Hub
- _____ NL Neo-Loc

E BODY HT. DIM.

- 5 1/4 [133]
- 3 3/4 [95]
- 5 1/4 [133]
- 4 5/8 [117]

PREFIXES

- ___ Z D.C.C.I. Body with Dome*
- ___ ZA D.C.C.I. Body with Aluminum Dome
- ___ ZRB D.C.C.I. Body with Plain Bronze Dome

SUFFIXES

- | | |
|---|---|
| ___ -AR Acid Resistant Epoxy Coated Finish | ___ -SS Stainless Steel Mesh Screen Over Dome |
| ___ -BS Bronze Mesh Screen Over Dome | ___ -TC Neo-Loc Test Cap Gasket
(2 - 4 [51 - 102] NL Bottom Outlet Only) |
| ___ -C Underdeck Clamp | ___ -VP Vandal-Proof Secured Top |
| ___ -DP Top-Set® Roof Deck Plate
(Replaces both the -C and -R) | ___ -XJ Vertical Expansion Joint (See Z190) |
| ___ -DR Top-Set® Drain Riser
(Adjustment from 3 5/8 [92] to 7 1/4 [184]) | ___ -84 Stainless Steel Perforated Gravel Guard |
| ___ -E 2 [51] High Static Extension (Specify Height) | ___ -85 Stainless Steel Perforated Extension |
| ___ -EB Top-Set® Adjustable Extension Assembly | ___ -89 2 [51] High External Water Dam |
| ___ -FG Flush Grate | ___ -90 90° Threaded Side Outlet Body
(2 - 4 [51 - 102]) (Previously Z124) |
| ___ -G Galvanized Cast Iron | |
| ___ -R Roof Sump Receiver | |
| ___ -SC Secondary Clamping Collar | |

REV. J DATE: 12/5/07 C.N. NO. 97795

DWG. NO. 58819 PRODUCT NO. Z121

*REGULARLY FURNISHED UNLESS OTHERWISE SPECIFIED

ZURN INDUSTRIES, LLC ♦ SPECIFICATION DRAINAGE OPERATION ♦ 1801 Pittsburgh Ave. ♦ Erie, PA 16514

Phone: 814/455-0921 ♦ Fax: 814/454-7929 ♦ World Wide Web: www.zurn.com

In Canada: ZURN INDUSTRIES LIMITED ♦ 3544 Nashua Drive ♦ Mississauga, Ontario L4V1L2 ♦ Phone: 905/405-8272 Fax: 905/405-1292